

ATCO NEWSLETTER

VOLUME 10 NUMBER 4

OCTOBER 1993

The ATCO newsletter is the official publication of a group of amateur television operators known as "AMATEUR TELEVISION IN CENTRAL OHIO" and is published quarterly (January, April, July, and October) Any re-publication of ATCO newsletter material without written consent is prohibited.

ATV REPEATER UPDATE

The ATV repeater is finally moving along and progressing at a faster pace. A number of significant events have taken place since last report. We finally got formal approval to locate the repeater on the roof of the State Office Tower in downtown Columbus!!! (For those of you that thought the signal looked good at 85 feet in the air, wait till you see it at 650 feet). A new antenna is finished and being tested at the present site. More equipment has been purchased to enhance the reliability. A 1258 mhz transmitter is just about finished to supplement the main output at 427.25 mhz. More details on the inside pages.

ATCO HAM IN THE SPOTLIGHT

The traveling camera caught Fred Yost (K8JGY) this time. I kid Fred a lot on net night about his parrot, Peety but now that I've met Peety I can see just what Fred is talking about. This bird actually ate part of the microphone cord to Fred's camera just to get his attention. I hope the bird knows the difference between a mike cord and a lamp cord. If not Fred, I think your problems are only short term. Seriously, it provides for a lot of good conversation on net night.

I believe Fred told me that he is fully retired now so I know we'll see him on the air more. Keep up the good work between you and your wife's help to make sure that the club's finances are in order.



ATV REPEATER PROGRESS SUMMARY from my workbench

Well, the tower maintenance reported last issue has been done! It was hard work but it is now a shiny shade of aluminum (cool color for a tower, huh) and the yagi antenna is replaced with a good 48 element broadside array (collinear for those of you that prefer to call it that - but that's another story). The 2 meter antenna also now works (I'm too ashamed to tell what was wrong with it). Now on to the repeater work before my wife finds out that the tower is finished and assigns another non-ATV related chore.

Well, the tower maintenance reported last issue has been done! It was hard work but it is now a shiny shade of
Well, the most time consuming job was to create a good 427.25 MHZ antenna. Since it's to be mounted with other commercial antennas 650 feet above street level, good strong mechanical construction was paramount. Also we wanted to maximize gain and achieve as much of an omnidirectional pattern as possible. After a number of designs were considered and tried, a slot design met most favorably. I set up an antenna test range in my back yard to prove (and disprove) some of the design ideas. After all, theoretical gain figures are seldom accurate in practice. (When's the last time you believed published gain figures?). After it was completed, we installed it in place of the miniwheel antenna at the present repeater site for a "shakedown test". Reports so far are consistent among hams in various Columbus locations which found at least 1 P unit improvement. Since the present antenna had roughly unity gain and my backyard tests indicate that the slot antenna has 7 DB gain, that makes sense (6DB per P unit).

A search was on for coax lines to connect the various antennas to the repeater. We need 4 runs of coax each to go approximately 60 feet from the top girder on the roof down to the transmitter house below it. The 910 MHZ and 147.45 MHZ link receive antennas will feed 1/2" Andrews Heliax and the 427.25 MHZ and 1258 MHZ transmit antennas will be fed with 7/8" Heliax. My search was rewarded at the Findlay Ohio hamfest in early September with an 85 foot length of 1/2" hardline but I came home empty handed on the search for 7/8" line. If we don't find some soon, the installation may be delayed.

Because of the location, it was very important that we install proper lightning protection for coax runs going into the transmitter room. A visual inspection revealed that all other equipment had proper protection and grounding. The facility provides a single point copper grounding buss bar to tie all equipment to so it is important that we install commercial protection units as well as utilize this single point ground. To date all protection units have been purchased and mounted to a plate which will be bolted to the equipment rack frame and connected to the buss with a heavy braided wire. In addition, AC line surge protectors will be installed at the 120VAC outlet.

I've started work on the 1258 MHZ transmitter and antenna at this time. The 2 watt driver is finished and working but the 20 watt final amp is not. Work is progressing slower on this phase because it conflicts with some preplanned interior decorating to our living and dining rooms (painting/wallpapering is not nearly as much fun as ATV work). I need about another week to finish up. If some coax shows up by that time, we're ready to install it.

While I've been working on antennas and the like, Ken (WA8RUT) has been quite busy also. Ken has decided that interdigital filters will be required for the 910 MHZ receive link signal as well as the 427.25 MHZ main transmitter output. They have been purchased and arrived awaiting final installation. Although not absolutely necessary for the transmitter it is a good thing to do to keep the airwaves clean and minimize any interference with our neighbors at the same location receiving 450 MHZ signals. Additionally a 910 MHZ transmitter and receiver has been purchased and received. The receive site (anonymous at this time-but a couple of alternates may surface) will need a preamp at the antenna so it is on order. All other receive site items seem to be adequate so no further work is needed here.

A 147.45 MHZ receiver at the transmit site will be required to control the 427 and 1258 MHZ transmitters. This is a difficult task because the area is already flooded with 150 MHZ strong signals and intermod will be difficult to control. Dale (WB8CJW) has decided to tackle this task. At this time he's got a receiver converted for this service with input capability on 147.45 as well as 144.34 MHZ. Sensitivity seems to be good but its rejection of unwanted intermod is yet to be demonstrated. We may have to try crosspolarization techniques among other things to get the rejection we need. He needs some more time to satisfactorily complete and package it.

That's all for now...Be sure to attend our ATV picnic on the 17th of this month for further updates.

A DUAL SLOT OMNIDIRECTIONAL ANTENNA FOR ATV REPEATER USE

Do you need a horizontally polarized omnidirectional gain antenna for 427 MHZ? Perhaps not, but that was exactly what was needed for the new ATCO repeater in Columbus Ohio. I was faced with the task of designing a mechanically strong antenna for our use. Now it would have been easy to just "throw money at it" and buy an antenna for our needs except for three main reasons: 1) no money 2) I don't trust adds that say "estimated gain ..." 3) A commercial horizontally polarized omni pattern antenna doesn't exist (TV broadcast excepted). Actually item #1 technically eliminates the necessity of exploring items 2 and 3. Probably most important, I like to design things like this-it's a challenge. I believe that this time it's **SUCCESS!!!**

A single slot antenna is described in numerous publications and functions as an infinite number of circular dipoles stacked in the vertical plane. It works most efficiently at 427 MHZ when the overall diameter is about 4 inches and the length of the slot is 2 wavelengths long. With those dimensions, the feed impedance is somewhere around 100 ohms. (The feed impedance figure was determined by experimentation because several articles claim anywhere from 200 to 100 ohms). I tried several impedance matching sections until the SWR was minimum. Considerable testing was done to verify that the single slot design was optimum before starting the dual version. When finished, an actual gain of 5 DB was obtained with a circular pattern to within 1.5 DB. The gain at the sides was down about 1.5 DB and rear gain was down 1 DB. Further testing was not able to improve upon this. There was always a condition where a more circular pattern resulted, but at the sacrifice of frontal gain so I stopped there and feel that it is optimum.

The addition of a second slot was not as straight forward as one may think. First, how far apart vertically should they be? Contrary to recommendations published for "stacking" the slots, 4.5 to 6 inch separation is not good. I found that gain dropped off noticeably after a separation of only 2 inches. I settled on a 1 inch separation which was the minimum practical distance and still be able to rotate them. For the record, no noticeable gain reduction occurred at 1 inch separation but started falling off at about 2 inches and was reduced by about 1.5 DB at a 4 inch separation. When we think about the reasons for this it seems that since the ends of each adjacent slot are the same phase and polarity ANY separation would tend to distort the pattern.

The way I constructed the slots allowed me to rotate each about the vertical axis to see if intentional misalignment would help the pattern. For all practical purposes, the slots want to be aligned. However I found that in my case at least, a slight misalignment of a few degrees helped the pattern slightly. A slight increase in gain of a few tenths of a DB was obtained. Certainly not significant enough to cause one to intentionally construct the antenna to adjust this. Even if you did, some good antenna measuring equipment is needed to be able to measure it.

The feed harness turned out to be quite simple. Since each slot had a feed impedance of about 100 ohms, two in parallel would exactly match a 50 ohm transmission line provided that each phasing line to the center was an even multiple of a wavelength (including the velocity factor of the coax). Note that the impedance of the phasing lines do not matter because they are exact multiples of a half wavelength. I realize this but found that RG11/U cable (75 ohms) was better by about 0.5 DB than Andrews 1/2 inch Superflex 50 ohm line even though the Andrews line had lower loss! I have no explanation for this because I ran out of line lengths and patience way before I stumbled upon the answer. Oh, by the way, for those of you that are saying you forgot the decoupling sleeve that's always required when you connect a balanced feed point to an unbalanced line, I didn't. I tried it and found no noticeable difference either way, so I left it off. Any guesses as to why this is so?

The final array as shown in the detail produces at least 7 DB of gain over a dipole with about - 2.5 DB on each side and -1.5 DB on the back. I don't like the side gain reduction but could not find any way to improve it without significantly sacrificing frontal gain. (When installed, we'll put the forward gain in the direction that does the most good). Final tuning is also required to both maximize gain and produce the lowest SWR. Two metal 1/2" x 1" tabs at the feed point spaced about 1/8" apart provided the required capacitance. Note, however, that slightly different slot widths will require a different capacitance. It is possible to construct the antenna with a slot so narrow that too much capacitance exists to start with. The addition of tabs would only make it worse.

I hope that my experiences and tests reported here will help someone else trying to build a slot antenna "from the book".

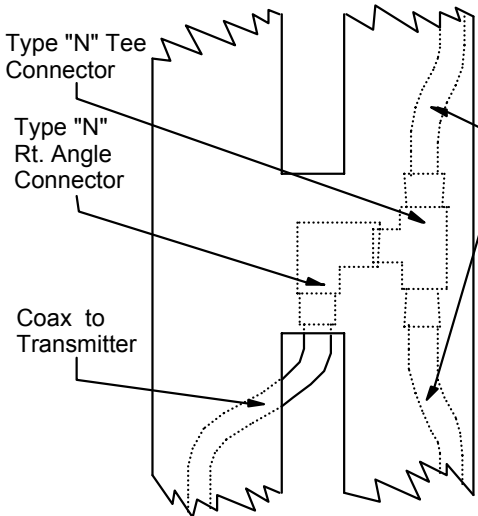
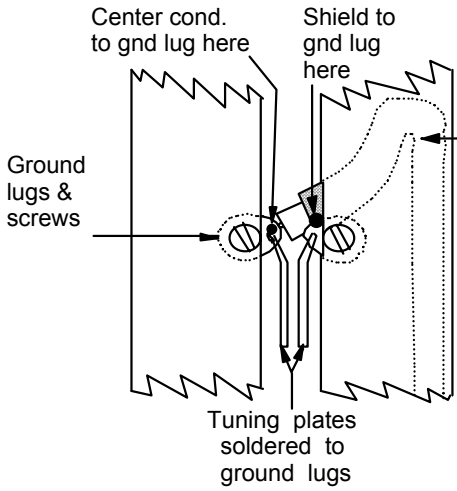

Each of these phasing lines must be even half wavelengths long from feed point to center of "T" connector. At 427.25 MHz and using RG11A coax, each one must be 36.5 inches.

$$2 \text{ wavelengths of RG11A coax} = \frac{23616}{\text{frequency(mhz)}} \cdot 0.66 = 36.48 \text{ inches}$$

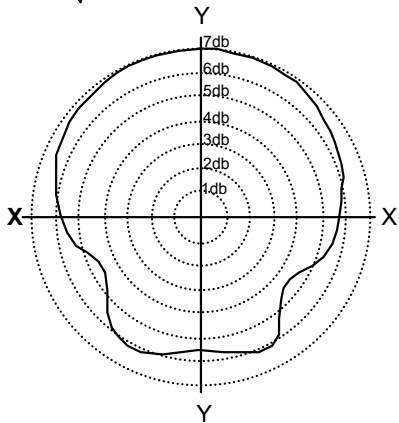

Antenna radiation pattern in the x-y plane. The z axis pattern is symetrical with 3db gain decrease at \square 20 degrees from vertical or horizontal axis.

0.62" slot width
3.87" tubing outside dia.

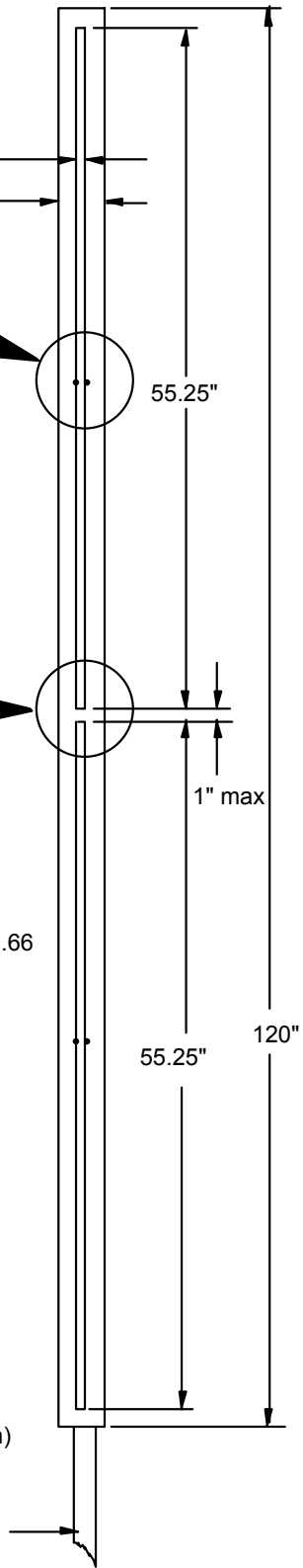

1" or 2" mast pipe.
Note: pipe may go into slot area, but no farther than 26 inches (1 wavelength) and must not come closer than 1 inch to slot.

The following is an excerpt from a letter I wrote to a fellow ham regarding the slot antenna. It contains some of my thinking at the time and is in addition to the article I wrote. 9/22/97 Art Towslee WA8RMC.

My ultimate goal for designing a slot antenna was for our club ATV repeater. After considering a number of designs, I settled on a slot antenna because of its inherent ruggedness for the top of a 47 story building in downtown Columbus Ohio. A dual slot was selected because, after experiments, I found the feed impedance of a single slot to be about 100 to 125 ohms. Therefore a dual (two singles in parallel) would be about 50 ohms and could be connected to a 50 ohm transmission line without impedance matching problems.

1. The length of each slot should be about 2 free space wavelengths long. This is not critical and could be shortened by a couple of inches or so before any noticeable gain reduction occurs. I'm told (I haven't verified this) that the design length could be 1 wavelength long and can be lengthened to up to 2 wavelengths for some additional gain. Lengthening it beyond that point would produce no further gain increase so that is why we stop there.
2. The slot width is a function of the diameter and should be widened as the diameter increases. I've found that about $\frac{1}{4}$ " is about right for a $3\frac{1}{2}$ " outer diameter. However, cut it a little narrow and test the antenna for gain and SWR. If 5db can't be obtained (single slot) and $7\frac{1}{2}$ db (dual slot) add small capacitance tabs at the feed point(s). If this makes it worse, widen the slot width about $\frac{1}{16}$ " and try again. The slot width is proper when the addition of a small amount of capacitance (1-2 pf) makes it better.
3. The diameter, I was told, is supposed to be optimum at about $3\frac{1}{2}$ " OD but I haven't found any substantiation for this. I've built one with $3\frac{1}{2}$ " OD pipe and one with $3\frac{3}{4}$ " OD pipe and both worked great. In fact, the one with the $3\frac{3}{4}$ " pipe produced about $\frac{1}{2}$ db higher gain (8db for a dual slot).
4. I've found that 3" or $3\frac{1}{2}$ " nominal aluminum electrical conduit is almost perfect for a dual slot design. They measure about $3\frac{1}{2}$ " and $3\frac{1}{4}$ " OD respectfully. They are 10 feet long and are threaded on each end which makes connection to a mast easy. Simply screw on a cap on the top end and a reducer on the other to reduce it to the mast size of your choice. This pipe is about $\frac{1}{4}$ " thick so it's fairly heavy. Use good hardware to attach it. Price for a 10 foot section is about \$40.00.
5. If you build the dual slot version, the phase harness length is somewhat critical. Use any impedance coax but be sure that each leg is a multiple of an electrical wavelength long. Best approach is to cut them a little long. Assemble it and test for the resonant frequency. Adjust the length accordingly. An error of $\frac{1}{4}$ " will change the resonant frequency about 5 Mhz!
6. I've found no need for an unbalance sleeve (Pausey stub) at the feedpoint. Although in theory it is necessary to use a balun to match a balanced feed to an unbalanced line, I found no measurable sacrifice by not doing so here. If you find otherwise, let me know.
7. Dual slot antennas must have the bottom of the top slot within an inch or so of the top of the bottom slot to prevent any gain loss. The commercial examples that show a single slot antenna mounted over the other creating a dual slot design are wrong.
8. I've found that all slot antennas have a gain notch at about 4 o'clock and again at about 8 o'clock. I measured this to be about 2 Db. If you find a way to eliminate it or explain why it's there, please let me know.
9. Measurement details. I have tested all of my antennas by supplying a 100-200 MW RF source fed into a gain antenna at one end of my yard with the test antenna (slot) about 75 feet away at the other end. I use a Boonton RF voltmeter connected to the slot with a cavity between to keep out unwanted local RF in the business band. Using the test antenna in receive mode seems to work best. Also it is helpful to angle the transmit antenna up from the ground to eliminate ground reflections. (That's why a dipole antenna can't be used at the source end.) If you do angle the test antenna up, remember to angle the slot for it must be perpendicular to the RF path.

I hope that I've given you some ideas to help your slot antenna construction. The construction article that I did was first published in our ATCO newsletter in July 1993 and re-published in the winter 1994 issue of ATVQ magazine.

DIRECTIONS TO THE ATCO FALL EVENT;

From I-70 either EAST or WEST Bound:

Take Route 315 (runs north and south and is just west of Columbus) and head NORTH. Get off at the Ackerman Road Exit and turn RIGHT on to Ackerman Road. Turn LEFT just beyond the first traffic light at the ATCO sign.

From I-71 traveling NORTH bound toward Columbus:

While traveling north on I-71, watch for the split to Route 315 just south of Columbus. Take 315 and head NORTH to the Ackerman Road Exit. Get off at this exit and turn RIGHT on to Ackerman Road. Turn LEFT just beyond the first traffic light at the ATCO sign.

From I-71 traveling SOUTH bound toward Columbus:

THESE DIRECTIONS ONLY WORK IF YOU ARE "NORTH" OF THE I-270 LOOP.

Take I-71 SOUTH to the I-270 Bypass Loop and head WEST on I-270. At the Route 315 Exit, turn LEFT and head SOUTH on Route 315. Get off at the Ackerman Road Exit and turn LEFT. Proceed through one traffic light and turn LEFT at the ATCO sign.

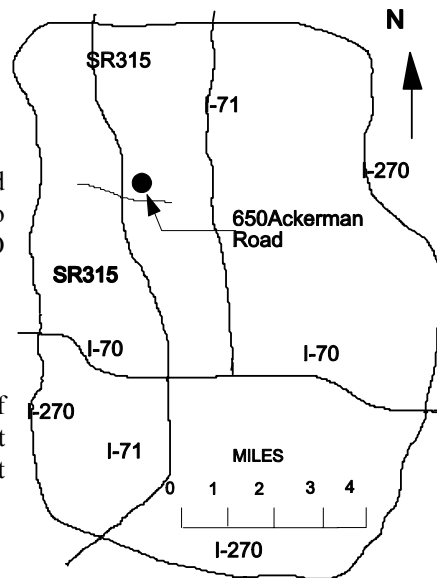

RECENT HAMFESTS

Both the Findlay and Cincinnati Hamfests turned out to be very good, if not great, hamfests. Findlay had its usual fine collection of ATV and TV related gear along with hard to find UHF parts and for me; tubes. The only problem this year was mother nature. If you didn't have your "looking around" done by about 12:00 noon, the wind "blew" the outside flea market away shortly thereafter. The worst hamfest, however, is better than the best day at work (I borrowed that from somewhere).

Cincinnati proved to also be a good hamfest in terms of hard to find parts (finger stock, SMA connectors, tubes, special caps, hardline, etc.). The weather was great and the crowds thin. The highlight of the day was the air show when a radio controlled helicopter picked up a toy stuffed bear in a floating chair in an adjacent lake. The bear parachuted out as the helicopter gained height and moved over dry land. The stunt looked great until the wind kicked up and swung the chair rope lines into the blades. Down went the chopper and the chair into the lake. The helicopter was retrieved shortly thereafter, but what a cleanup must be in store for the owner. (From the looks of it, I would say it will definitely be worth it. Those things can't be cheap.)

WA3DTO

DX NEWS

There have been several 70 CM band openings in the last few months. I have personally had good luck in working Don Miller, W9NTP, in Waldron, IN (just southeast of Indianapolis) many times in the morning. There have been several good openings to the South near Cincinnati with WB8GRS and WA8ZAH, on net nights. On Saturday, September 25th, there was an exceptional opening into Jackson, MI, during the early morning hours. Folks around the Dayton/Spring-field area worked N8AR, P5 and I was able to work him P3. 23 CM has been no slouch either with WB8URI working into Cleveland, OH, late one evening. Openings have generally been good to the South and the West. More DX News should be available at the Fall Event, Sunday, October 17, 1993, at 1:00 PM.

WA3DTO

ATV LOCATOR MAP

This time I am going to try something new hoping that it will catch on. On the following page I've created an Ohio map complete with counties, main cities, beam heading (from Columbus) and all of the hams that I know of that have had video on the air this year. Obviously I've missed a number of people but I hope that you will help me fill it in. Please report to me anyone that you know of that has had video on and you have seen in the last year. If video is not reported for a given individual in about a year, I will remove that one from the map. The goal here is to have at a glance, a list and location of the most ATV activity. Lets see if we can make Ohio near the top for ATV activity. I've not indicated whether it has been 439 and 1280 MHZ activity but if I get good info, I'll make a distinction on the map in the future.

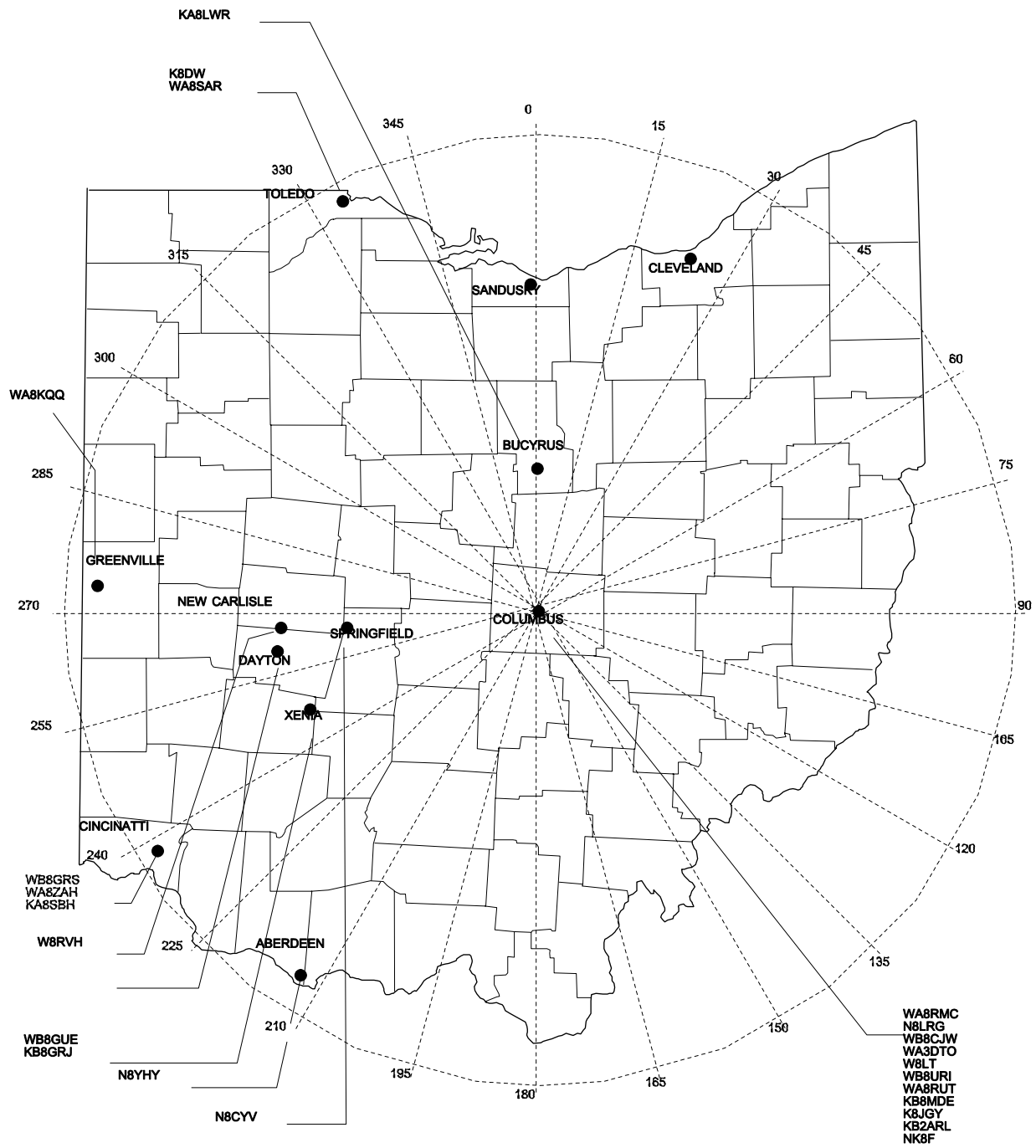

Active ATV'ers in Ohio

ATCO MEMBERSHIP INFORMATION

Membership in ATCO (Amateur Television in Central Ohio) is open to any licensed radio amateur who has an interest in amateur television. The annual dues are \$10.00 per person payable on January 1 of each year. Additional members within an immediate family are included at no extra cost.

ATCO publishes the ATCO newsletter quarterly in January, April, July, and October. The newsletter is sent to each member without additional cost.

The membership period is from January 1ST to December 31ST. New Members will receive all ATCO newsletters published during the current year prior to the date they join ATCO. For example, a new member joining in June will receive the January and April issues in addition to the July and October issues.

Your support of ATCO is welcomed and encouraged.

ATCO MEMBERSHIP APPLICATION

RENEWAL NEW MEMBER DATE _____
NAME _____ CALL _____
ADDRESS _____ HOME PHONE _____
CITY _____ STATE _____ ZIP _____
FCC LICENSED OPERATORS IN THE IMMEDIATE
FAMILY _____

COMMENTS

ANNUAL DUES PAYMENT OF \$10.00 ENCLOSED CHECK CASH
Make check payable to Martha Yost (for Fred Yost-ATCO treasurer) & mail to:

Fred Yost K8JGY
330 Dellfield Way
Gahanna, Ohio
43230

ATCO MEMBERS AS OF 01 JULY 1993

| | | | | | |
|--------|-------------------|-------------------------|----------------|----------|-------|
| K8AEH | Wilbur Wollerman | 1672 Rosehill Road | Reynoldsburg | Ohio | 43068 |
| W8AER | Dave Sears | 1678 Kaiser Dr | Reynoldsburg | Ohio | 43068 |
| AH2AR | David Pelaez | 4872 Trailside Court | Huber Heights | Ohio | 45424 |
| KB2ARL | Dave DiGiuseppe | 391-3A Directory Dr | Columbus | Ohio | 43213 |
| WB8BIY | Robert Shaw | 82 Troy Court | Westerville | Ohio | 43081 |
| WB8CJW | Dale Elshoff | 8904 Winoak Pl | Powell | Ohio | 43065 |
| N8CYV | Blaire Standley | 721 West North St | Springfield | Ohio | 45504 |
| WA3DTO | Rick White | 5314 Grosbeak Glen | Orient | Ohio | 43146 |
| W8EHW | Foster Warren | 124 East Clark St | North Hampton | Ohio | 45349 |
| WD8EMS | Lee Coyle | 7495 Lithopolis Road | Groveport | Ohio | 43125 |
| WA8EOY | Jonh Schlaechter | 3199 Lewis Rd | Columbus | Ohio | 43207 |
| KA8ERS | Rick Shepherd | 3296 Karl Road | Columbus | Ohio | 43224 |
| NK8F | Rich Budd | 734 Hager Court | Gahanna | Ohio | 43230 |
| N8FFO | Edward Hauff | 2716 Columbus Ave | Columbus | Ohio | 43209 |
| KB9FO | Henry Ruh | 1545 Lee St Suite 73 | Des Plaines | Illinois | 60018 |
| KB8GZO | Jason Pelaez | 4872 Trailside Court | Huber Heights | Ohio | 45424 |
| KA8GZQ | Warren Duemmel | 3488 Darbyshire Dr | Hilliard | Ohio | 43026 |
| K8HRR | Ira Bickham | 260 Tiki Dr | Merritt Island | Florida | 32953 |
| N0IKJ | Ruth Budd | 734 Hager Court | Gahanna | Ohio | 43230 |
| K8JGY | Fred Yost | 330 Dellfield Way | Gahanna | Ohio | 43230 |
| N8KCB | Chris Morris | 3181 Gerbert Rd | Columbus | Ohio | 43224 |
| WA8KQQ | Dale Waymire | 225 Riffle Ave | Greenville | Ohio | 45331 |
| WB8LGA | Chuck Beener | 2548 State Route 61 | Marengo | Ohio | 43334 |
| N8LRG | Phillip Humphries | 1237 Summer Breeze Dr | Columbus | Ohio | 43223 |
| N8MCQ | John Unverzagt | 159 Chapelfield Road | Gahanna | Ohio | 43230 |
| KB8MDE | Shaun Miller | 3469 Oakcrest Rd | Columbus | Ohio | 43232 |
| N8OOY | Cheryl Taft | 386 Cherry Street | Groveport | Ohio | 43125 |
| N8OPB | Chris Huhn | 146 South Hague Ave | Columbus | Ohio | 43204 |
| WB8OTH | Perry Yantis | 1850 Lisle Ave | Obetz | Ohio | 43207 |
| KE8PN | James Easley | 1507 Michigan Ave | Columbus | Ohio | 43201 |
| KF8QU | Bob Tournoux | 3569 Oarlock Ct | Hilliard | Ohio | 43026 |
| N8QLD | Rick Callebs | P.O. Box 266 | Jackson | Ohio | 45640 |
| WA8RMC | Art Towslee | 180 Fairdale Ave | Westerville | Ohio | 43081 |
| WA8RUT | Ken Morris | 3181 Gerbert Rd | Columbus | Ohio | 43224 |
| W8RVH | Richard Goode | 9391 Ballentine Rd | New Carlisle | Ohio | 45334 |
| WA8SAR | Gary Obee | 3691 Chamberlain | Lambertville | Mich | 48144 |
| WA8TTE | Phil Morrison | 154 Llewellyn Ave | Westerville | Ohio | 43081 |
| N8TUU | Maxine Duemmel | 3488 Darbyshire Dr | Hilliard | Ohio | 43206 |
| W8TV | Bob Dye | 6118 Sedgwick Rd | Columbus | Ohio | 43235 |
| KE8U | John Green | 7585 Central College Rd | New Albany | Ohio | 43054 |
| WB8URI | William Heiden | 4435 Kaufman Rd | Plain City | Ohio | 43064 |
| KA8WGX | Martha Yost | 330 Dellfield Way | Gahanna | Ohio | 43230 |
| KA8ZNY | Tom Taft | 386 Cherry Street | Groveport | Ohio | 43125 |

ATCO FINANCIAL STATEMENT

| | |
|------------------------------------|----------|
| CASH BALANCE (as of 07/01/93)..... | \$803.91 |
| RECEIPTS (dues)..... | \$0.00 |
| OTHER INCOME | \$0.00 |
| EXPENDITURES (postage)..... | \$-14.50 |
| BALANCE (as of 07/01/93)..... | \$789.41 |

ATCO Newsletter
c/o Art Towslee-WA8RMC
180 Fairdale Ave
Westerville, Ohio
43081

29c
postage
here

FIRST CLASS MAIL

**DID YOU ENJOY YOUR SUMMER!!
NOW THAT SUMMER CHORES ARE DONE,
SERIOUS ATV WORK CAN RESUME!!!**
